



Fastener
Solutions

11" Standard Cable Ties Marketing Specifications

For the following part numbers:

08056-0
08056-HHBN
08286-0
08600-0
08859-0
08930-0

August 1, 2018

AVERY DENNISON MARKETING SPECIFICATION

HISTORY

THE SUBJECT MATTER DISCLOSED HEREIN EMBODIES PROPRIETARY INFORMATION WHICH IS THE CONFIDENTIAL PROPERTY OF THE AVERY DENNISON CO. NONE OF WHICH SHALL BE COPIED, REPRODUCED, DISCLOSED TO OTHERS, PUBLISHED OR USED IN WHOLE OR IN PART, FOR ANY PURPOSE OTHER THAN THAT FOR WHICH IT IS BEING MADE AVAILABLE WITHOUT THE EXPRESS ADVANCE WRITTEN PERMISSION OF A DULY AUTHORIZED AGENT OF THE COMPANY. THIS DOCUMENT IS THE PROPERTY OF THE AVERY DENNISON CO. AND IS TO BE RETURNED TO THE COMPANY ON DEMAND.

REV.	DATE	DESCRIPTION
A	2/27/17	INITIAL RELEASE

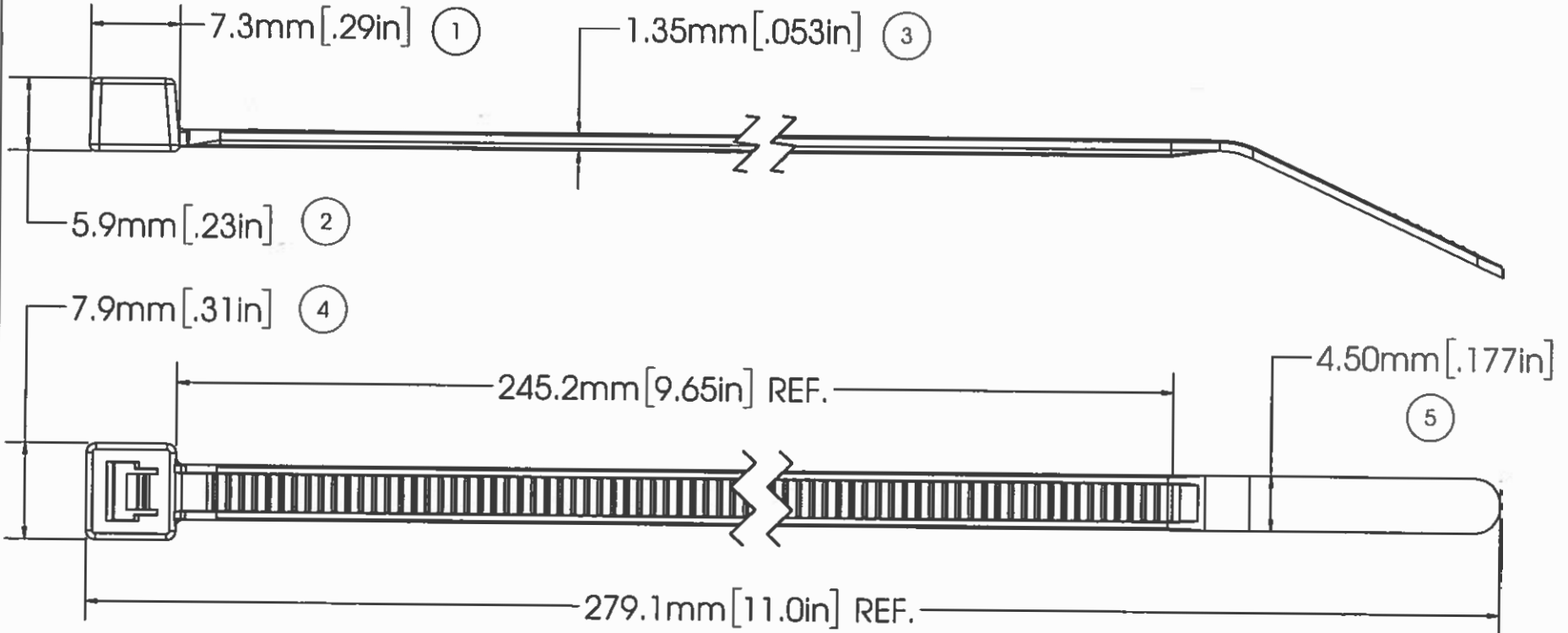

NOTES:

1. Δ INDICATES A SPECIAL CHARACTERISTIC

⑥	Δ LOOP TENSILE:	50 LBF / 220N MIN.
⑦	Δ FLAMMABILITY:	HB RATED PER FMVSS302
	OPERATING TEMP:	-40°F (-40°C) TO 302°F (150°C) CONTINUOUS AND 329°F (165°C) MAX EXPOSURE
	MIN. INSTALLATION TEMP:	32°F (0°C)
	WEIGHT:	1.8 g / .06 oz
	BUNDLE DIAMETER:	1.59mm - 76.2mm
	TOOL:	12001 - HAND INSTALLATION TOOL 12500 - PNUEM. INSTALLATION TOOL
	TOOL TENSION SETTING:	6 - 8
	PACKAGING:	1000/BAG 5000/CASE

APPROVALS:

ENG. APPR. *Phil Long* 2/27/17
Q.A. APPR. *Walter Wallard* 2/27/17

SPECIFIED TOLERANCES ARE:

.XX ± .03 IN. .X ± .7 MM
.XXX ± .010 IN. .XX ± .25 MM
ANGULAR: ± 2°

MATERIAL
NYLON 6/6, IMPACT
MODIFIED HEAT STABILIZED

COLOR
BROWN



FASTENER DIVISION
FITCHBURG, MA 01420 U.S.A.
TEL. 1-800-225-5913
FAX. 978-353-8157

DESCRIPTION
11" CABLE TIE, STD, HIGH HEAT

STOCK NO.
08056-HHBN

REV.
A

5

4

3

2

1

AVERY DENNISON MARKETING SPECIFICATION

HISTORY		
REV.	DATE	DESCRIPTION
H	01.21.13	UPDATED TO THE NEW FORMAT; UPDATED GEOMETRY TO MATCH PART
I	03.15.13	UPDATED BALLOON 5
J	1-22-15	ADDED MIN INSTALL TEMP: UL LOGO AND 5000 PER CASE CHG LOOP TENSILE TO NEWTONS

THE SUBJECT MATTER DISCLOSED HEREIN EMBODIES PROPRIETARY INFORMATION WHICH IS THE CONFIDENTIAL PROPERTY OF THE AVERY DENNISON CO. NONE OF WHICH SHALL BE COPIED, REPRODUCED, DISCLOSED TO OTHERS, PUBLISHED OR USED IN WHOLE OR IN PART, FOR ANY PURPOSE OTHER THAN THAT FOR WHICH IT IS BEING MADE AVAILABLE WITHOUT THE EXPRESS ADVANCE WRITTEN PERMISSION OF A DULY AUTHORIZED AGENT OF THE COMPANY. THIS DOCUMENT IS THE PROPERTY OF THE AVERY DENNISON CO. AND IS TO BE RETURNED TO THE COMPANY ON DEMAND.

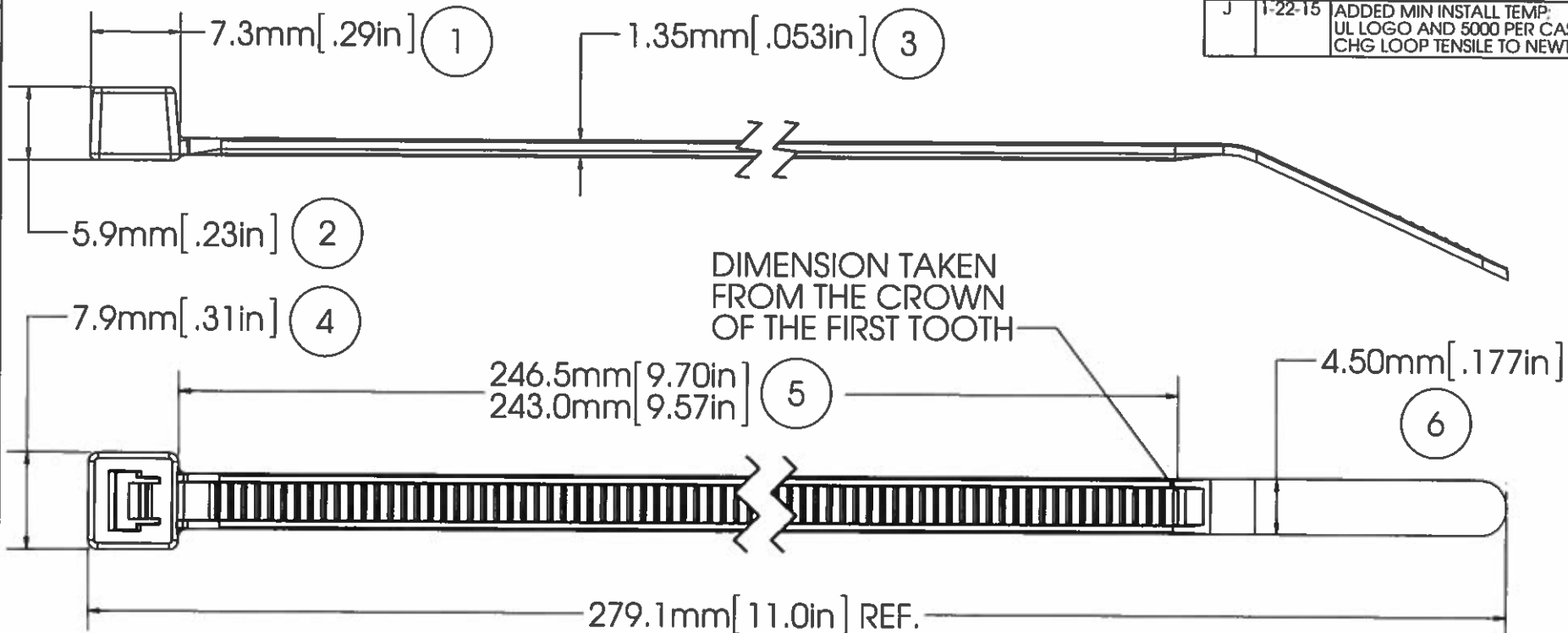

NOTE: THESE CABLE TIES ARE PLENUM RATED AND HAVE A FLAMMABILITY RATING OF V-2



LOOP TENSILE STRENGTH:.	50 LBF / 220N MIN. PER AS-23190
OPERATING TEMP:.	-40°F (-40°C) TO 220°F (105°C)
MIN. INSTALLATION TEMP:.	32°F(0°C)
WEIGHT:.	0.061 OZ./1.80 GRAMS
BUNDLE DIAMETER:.	1.59mm - 76.2mm
TOOL:.	12001 - HAND INSTALLATION TOOL 12500 - PNUEM. INSTALLATION TOOL
TOOL TENSION SETTING:.	6 - 8
PACKAGING:.	1000/BAG 5000/CASE

APPROVALS:	ENG. APPR. <i>[Signature]</i> 1/22/15
	Q.A. APPR. <i>[Signature]</i> 1/22/15
SPECIFIED TOLERANCES ARE:	
.XX ± .03 IN.	.X ± .7 MM
.XXX ± .010 IN.	.XX ± .25 MM
ANGULAR: ± 2°	

AVERY DENNISON <small>FASTENER DIVISION FITCHBURG, MA 01420 U.S.A. TEL. 1-800-225-5913 FAX. 978-353-8157</small>	DESCRIPTION	11" CABLE TIE, STD
	STOCK NO.	08056-0
REV.	J	

5 4 3 2 1

AVERY DENNISON MARKETING SPECIFICATION

HISTORY

THE SUBJECT MATTER DISCLOSED HEREIN EMBODIES PROPRIETARY INFORMATION WHICH IS THE CONFIDENTIAL PROPERTY OF THE AVERY DENNISON CO. NONE OF WHICH SHALL BE COPIED, REPRODUCED, DISCLOSED TO OTHERS, PUBLISHED OR USED IN WHOLE OR IN PART, FOR ANY PURPOSE OTHER THAN THAT FOR WHICH IT IS BEING MADE AVAILABLE WITHOUT THE EXPRESS ADVANCE WRITTEN PERMISSION OF A DULY AUTHORIZED AGENT OF THE COMPANY. THIS DOCUMENT IS THE PROPERTY OF THE AVERY DENNISON CO. AND IS TO BE RETURNED TO THE COMPANY ON DEMAND.

REV.	DATE	DESCRIPTION
H	1-22-15	ADDED MIN INSTALL TEMP: UL LOGO AND 5000 PER CASE CHG LOOP TENSILE TO NEWTONS

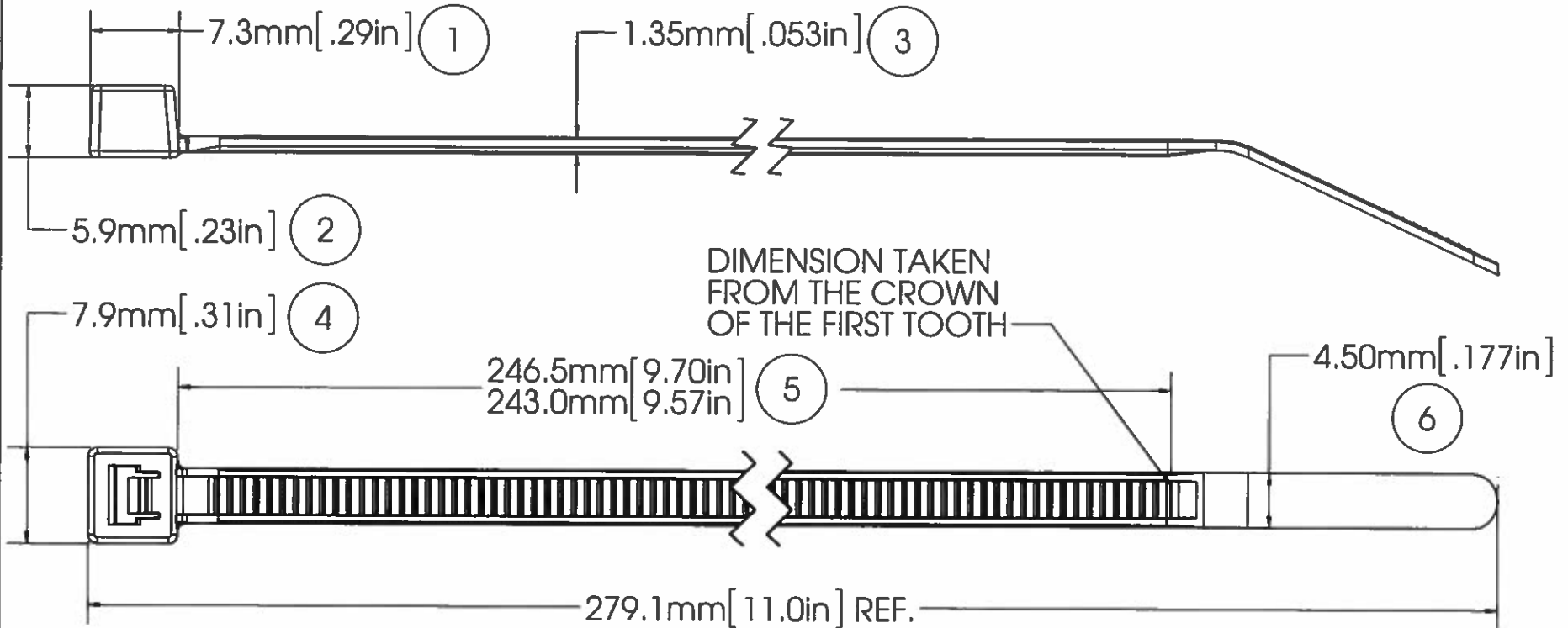

NOTE: THESE CABLE TIES ARE UV RESISTANT AND HAVE A FLAMMABILITY RATING OF V-2



MILITARY STANDARD:	MS-3367-7-0
LOOP TENSILE STRENGTH:	50 LBF / 220N MIN. PER AS-23190
OPERATING TEMP.:	-40°F (-40°C) TO 176°F (80°C)
MIN. INSTALLATION TEMP.:	32°F(0°C)
WEIGHT:	0.061 OZ./1.80 GRAMS
BUNDLE DIAMETER:	1.59mm - 76.2mm
TOOL:	12001 - HAND INSTALLATION TOOL 12500 - PNUM. INSTALLATION TOOL
TOOL TENSION SETTING:	6 - 8
PACKAGING:	1000/PACKS 5000/CASE

APPROVALS:	ENG. APPR. <i>D. O. M.</i> 1/22/15
	Q.A. APPR. <i>J. Boyle</i> 1/22/15
SPECIFIED TOLERANCES ARE:	
.XX ± .03 IN.	.X ± .7 MM
.XXX ± .010 IN.	.XX ± .25 MM
ANGULAR: ± 2°	

AVERY DENNISON <small>FASTENER DIVISION FITCHBURG, MA 01420 U.S.A. TEL. 1-800-225-6913 FAX. 978-353-8157</small>	DESCRIPTION	11" CABLE TIE, STD
	STOCK NO.	08286-0
	REV.	H

AVERY DENNISON MARKETING SPECIFICATION

HISTORY

REV.	DATE	DESCRIPTION
H	1-22-15	ADDED MIN INSTALL TEMP; UL LOGO AND 5000 PER CASE CHG LOOP TENSILE TO NEWTONS

THE SUBJECT MATTER DISCLOSED HEREIN EMBODIES PROPRIETARY INFORMATION WHICH IS THE CONFIDENTIAL PROPERTY OF THE AVERY DENNISON CO. NONE OF WHICH SHALL BE COPIED, REPRODUCED, DISCLOSED TO OTHERS, PUBLISHED OR USED IN WHOLE OR IN PART, FOR ANY PURPOSE OTHER THAN THAT FOR WHICH IT IS BEING MADE AVAILABLE WITHOUT THE EXPRESS ADVANCE WRITTEN PERMISSION OF A DULY AUTHORIZED AGENT OF THE COMPANY. THIS DOCUMENT IS THE PROPERTY OF THE AVERY DENNISON CO. AND IS TO BE RETURNED TO THE COMPANY ON DEMAND.

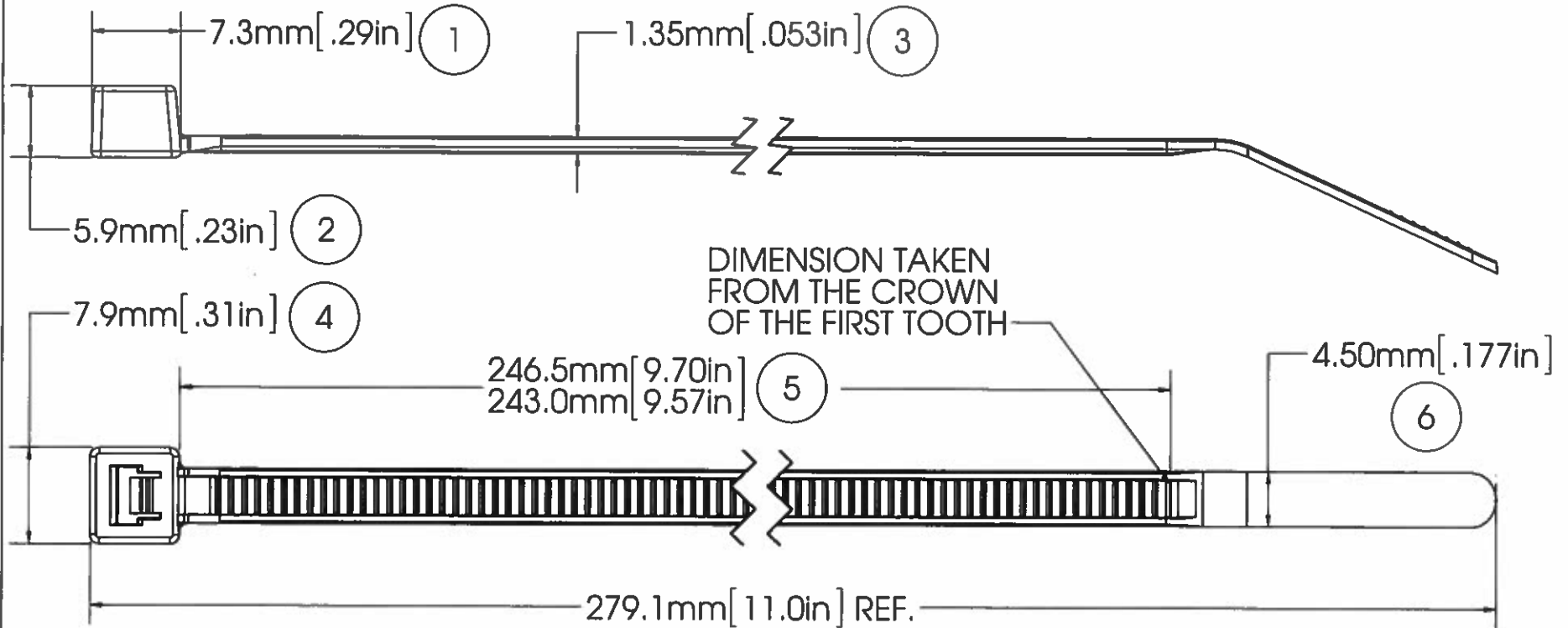

NOTE: THESE CABLE TIES ARE PLENUM RATED AND HAVE A FLAMMABILITY RATING OF V-2



MILITARY STANDARD:	MS-3367-7-9
LOOP TENSILE STRENGTH:	50 LBF / 220N MIN. PER AS-23190
OPERATING TEMP.:	-40°F (-40°C) TO 185°F (85°C)
MIN. INSTALLATION TEMP.:	32°F (0°C)
WEIGHT:	0.061 OZ. / 1.80 GRAMS
BUNDLE DIAMETER:	1.59mm - 76.2mm
TOOL:	12001 - HAND INSTALLATION TOOL 12500 - PNUEM. INSTALLATION TOOL
TOOL TENSION SETTING:	6 - 8
PACKAGING:	1000/BAG 5000/CASE

APPROVALS: ENG. APPR. *D. O. A. G. 1/22/15*
Q.A. APPR. *J. Boyce 2/22/15*



FASTENER DIVISION
FITCHBURG, MA 01420 U.S.A.
TEL. 1-800-225-5913
FAX. 978-353-8157

SPECIFIED TOLERANCES ARE:
.XX ± .03 IN. .X ± .7 MM
.XXX ± .010 IN. .XX ± .25 MM
ANGULAR: ± 2°

MATERIAL: **NYLON 6/6**
COLOR: **NATURAL**

DESCRIPTION: **11" CABLE TIE, STD**
STOCK NO.: **08600-0**
REV.: **H**

AVERY DENNISON MARKETING SPECIFICATION

THE SUBJECT MATTER DISCLOSED HEREIN EMBODIES PROPRIETARY INFORMATION WHICH IS THE CONFIDENTIAL PROPERTY OF THE AVERY DENNISON CO. NONE OF WHICH SHALL BE COPIED, REPRODUCED, DISCLOSED TO OTHERS, PUBLISHED OR USED IN WHOLE OR IN PART, FOR ANY PURPOSE OTHER THAN THAT FOR WHICH IT IS BEING MADE AVAILABLE WITHOUT THE EXPRESS ADVANCE WRITTEN PERMISSION OF A DULY AUTHORIZED AGENT OF THE COMPANY. THIS DOCUMENT IS THE PROPERTY OF THE AVERY DENNISON CO. AND IS TO BE RETURNED TO THE COMPANY ON DEMAND.

HISTORY

REV.	DATE	DESCRIPTION
B	1-22-15	ADDED MIN INSTALL TEMP: UL LOGO AND 5000 PER CASE CHG LOOP TENSILE TO NEWTONS

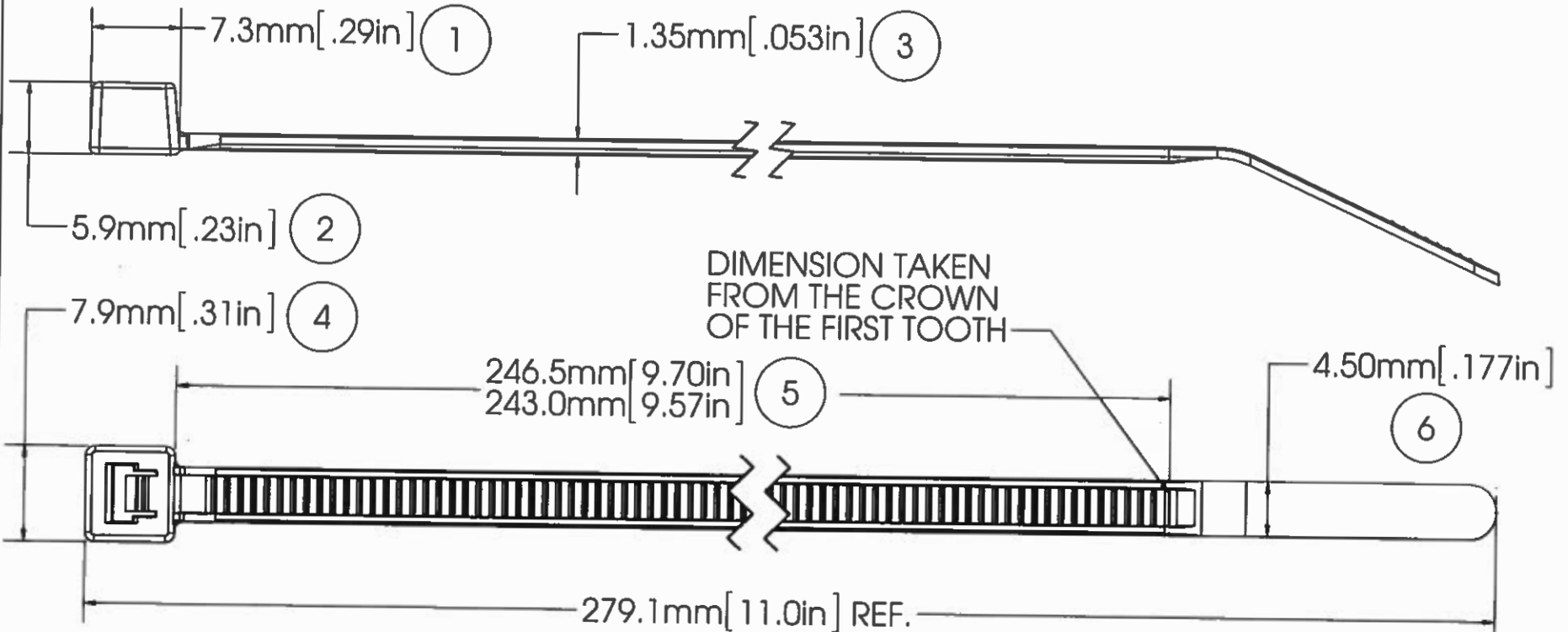

NOTE: THESE CABLE TIES ARE UV RESISTANT AND HAVE A FLAMMABILITY RATING OF V-2



MILITARY STANDARD:	MS-3367-7-0
LOOP TENSILE STRENGTH:	50 LBF / 220N MIN. PER AS-23190
OPERATING TEMP.:	-40°F (-40°C) TO 176°F (80°C)
MIN. INSTALLATION TEMP.:	32°F (0°C)
WEIGHT:	0.061 OZ./1.80 GRAMS
BUNDLE DIAMETER:	1.59mm - 76.2mm
TOOL:	12001 - HAND INSTALLATION TOOL 12500 - PNUEM. INSTALLATION TOOL
TOOL TENSION SETTING:	6 - 8
PACKAGING:	100/BAG 5000/CASE

APPROVALS:	ENG. APPR. <i>D. O'Neil</i> 1/22/15
	Q.A. APPR. <i>J. Boyle</i> 1/22/15
SPECIFIED TOLERANCES ARE:	
.XX ± .03 IN.	.X ± .7 MM
.XXX ± .010 IN.	.XX ± .25 MM
ANGULAR: ± 2°	

	AVERY DENNISON	FASTENER DIVISION FITCHBURG, MA 01420 U.S.A. TEL. 1-800-225-5913 FAX. 978-353-8157
DESCRIPTION		11" CABLE TIE, STD
STOCK NO.	08930-0	REV. B

5

4

3

2

1